



SoHyFIS-Yager: A self-organizing Yager based Hybrid neural Fuzzy Inference System

S.W. Tung, C. Quek*, C. Guan

Center for Computational Intelligence, Block N4 #2A-32, School of Computer Engineering, Nanyang Technological University, Nanyang Avenue, Singapore 639798, Singapore

ARTICLE INFO

Keywords:

HyFIS
Gaussian Discrete Incremental Clustering
Yager inference
Noise handling
Fuzzy systems
Neural networks
Neuro-fuzzy systems
Mackey–Glass prediction
Iris classification
Ovarian cancer diagnosis

ABSTRACT

The Hybrid neural Fuzzy Inference System (HyFIS) is a multilayer adaptive neural fuzzy system for building and optimizing fuzzy models using neural networks. In this paper, the fuzzy Yager inference scheme, which is able to emulate the human deductive reasoning logic, is integrated into the HyFIS model to provide it with a firm and intuitive logical reasoning and decision-making framework. In addition, a self-organizing gaussian Discrete Incremental Clustering (gDIC) technique is implemented in the network to automatically form fuzzy sets in the fuzzification phase. This clustering technique is no longer limited by the need to have prior knowledge about the number of clusters present in each input and output dimensions. The proposed self-organizing Yager based Hybrid neural Fuzzy Inference System (SoHyFIS-Yager) introduces the learning power of neural networks to fuzzy logic systems, while providing linguistic explanations of the fuzzy logic systems to the connectionist networks. Extensive simulations were conducted using the proposed model and its performance demonstrates its superiority as an effective neuro-fuzzy modeling technique.

© 2012 Published by Elsevier Ltd.

1. Introduction

Neural fuzzy networks are hybrid systems that capitalize on the functionalities of fuzzy systems and neural networks (Nauck, Klawonn, & Kruse, 1997). Despite its excellent explanatory powers as a linguistic model using a set of highly intuitive and easily comprehensible IF-THEN fuzzy rules, a fuzzy logic system does not have the learning power to automatically determine the membership degrees of its membership functions. On the other hand, a neural network (Haykin, 1998) possesses great learning capabilities and its distributed structures caters for highly parallel computations, in spite of its inability to integrate knowledge into or to extract it from the structures. By synergizing fuzzy logic systems with neural networks, neural fuzzy systems incorporate high-level human-like reasoning with low-level computational learning, and this enables them to model a problem using vague information by means of a set of linguistic IF-THEN fuzzy rules, while possessing learning abilities to self-adjust the parameters of the fuzzy rules. This is an improved tool over the individual systems of fuzzy logic and neural networks because the drawbacks of the individual systems such as the lack of learning abilities in a fuzzy logic system and the black-box phenomenon in a neural network are resolved.

Existing neural fuzzy systems can be generally classified into two groups: (1) systems with self-tuning capabilities whose initial rulebase must be known prior to training (Horikawa, Furuhashi, &

Ucbikawa, 1992; Jang, 1993) and (2) systems that derive their initial rulebase from numerical data and thereafter, perform parameter training on the fuzzy rules (Castellano & Fanelli, 2000; Kim & Kasabov, 1999; Lin & Lee, 1991; Tung & Quek, 2002; Quek & Zhou, 1996). The main advantage that the latter group of neural fuzzy systems has over the former is that it might be difficult to obtain a consistent initial fuzzy rulebase for the networks in the former case. This could be due to the difficulty that human experts encounter when attempting to verbalize their knowledge and expressing it in terms of a set of IF-THEN fuzzy rules for complex systems. In addition, we can further sub-categorize the latter group of neural fuzzy systems into (a) systems that adopt partition-based clustering techniques (Kim & Kasabov, 1999; Lin & Lee, 1991; Quek & Zhou, 1996); and (b) systems with self-organizing abilities (Castellano & Fanelli, 2000; Tung & Quek, 2002). By adopting partition-based clustering techniques such as fuzzy C-means (Bezdek, 1981), linear vector quantization (Kohonen, 1982) and fuzzy Kohonen partitioning (Bezdek, Tsao, & Pal, 1992), it results in a weakened resistance in the neural fuzzy systems towards noisy training data. This is because clustering using partition-based techniques requires prior knowledge about the number of clusters present in the input–output dimensions, and this results in a lack of flexibility in handling non-partitionable problems.

The Hybrid neural Fuzzy Inference System (HyFIS) (Kim & Kasabov, 1999) is an adaptive neural fuzzy system that is used to combine numerical and linguistic information into a common framework. It adopts a two phase learning scheme where knowledge is first acquired from the numerical training data, and this is subsequently followed by a parameter tuning process. In the first

* Corresponding author. Tel.: +65 6790 4926; fax: +65 6792 6559.

E-mail addresses: swtung@pmail.ntu.edu.sg (S.W. Tung), ashcquek@ntu.edu.sg (C. Quek), ctguan@i2r.a-star.edu.sg (C. Guan).

phase, which is known as the knowledge acquisition phase, a fuzzy technique of Wang and Mendel (1992) is used to derive the initial fuzzy rulebase from the desired training input–output data pairs, and hence established the initial structure of the neural fuzzy system. Information about the number of clusters in each of the dimensions is priorly determined by the user. In the second phase, the network adaptively fine-tunes membership functions of the input and output dimensions using a gradient descent based parameter learning technique.

This paper proposes the self-organizing Yager based Hybrid neural Fuzzy Inference System (SoHyFIS-Yager), which emulates the human deductive inference and reasoning decision-making mechanism. In the proposed model, the gaussian Discrete Incremental Clustering (gDIC) (Nguyen, Shi, & Quek, 2005) technique for gaussian membership functions is implemented in the initialization phase of the SoHyFIS-Yager network to overcome the need for prior knowledge about the number of clusters present in the input–output dimensions. This enables the knowledge acquisition phase of the SoHyFIS-Yager learning scheme to be entirely data-driven such that separate clusters are formed for outliers/noisy data that share a poor correlation with the genuine desired input–output pairs, and hence allowing the proposed model to robustly handle noisy data while preserving the dynamism of partition-based clustering techniques. The Discrete Incremental Clustering (DIC) (Tung & Quek, 2002) technique was first proposed for trapezoidal membership functions in the GenSoFNN model (Tung & Quek, 2002) to overcome the need for prior knowledge during cluster analysis in the rule formation phase of the network. In addition, the fuzzy Yager inference (Keller, Yager, & Tahani, 1992) scheme, which is able to emulate the human deductive reasoning logic, is implemented in the proposed SoHyFIS-Yager model to provide it with a firm and intuitive logical reasoning and decision-making framework. It is an enhancement of the HyFIS model, which adopts the Compositional Rule of Inference (CRI) (Zadeh, 1975) scheme involving composition operations that are conceptually unclear (Turksen & Zhong, 1990). A major advantage of adopting the fuzzy Yager inference scheme is its ability to produce the outputs that are the exact consequents of the fuzzy rule when the inputs perfectly matches the crisp antecedents of the fuzzy rule. In this sense, the fuzzy Yager inference is able to mimic the human-like deductive logic mechanism, and offers the proposed

SoHyFIS-Yager model with a firmer and more intuitive logical reasoning and decision-making framework.

The rest of the paper is organized as follows: Section 2 describes the architecture, inference scheme and the learning process of the proposed SoHyFIS-Yager model; the correspondence between the functionalities of the SoHyFIS-Yager model and the Yager inference scheme is presented in Section 3; in Section 4, the SoHyFIS-Yager is evaluated using three different simulations and its performances are benchmarked against other neural and neural fuzzy systems; and Section 5 concludes this paper.

2. SoHyFIS-Yager

The proposed SoHyFIS-Yager model (Fig. 1) adopts a two phase learning paradigm: knowledge acquisition, and parameter learning. In its initial form, there is no membership function, fuzzy partition, and fuzzy rule in the proposed model. The gDIC (Nguyen et al., 2005) clustering technique is implemented during the knowledge acquisition phase to automatically perform fuzzy partitioning of the input–output dimensions based on the numerical training data, and fuzzy rules are subsequently extracted by using the fuzzy technique proposed by Wang and Mendel (Wang & Mendel, 1992). It is a one-pass build-up procedure for generating fuzzy rules from the partitioned input–output dimensions. This is followed by a supervised parameter learning process. The error back-propagation (Haykin, 1998) learning algorithm based on the gradient descent approach is employed to tune the parameters in the SoHyFIS-Yager model.

2.1. Architecture of the SoHyFIS-Yager

The SoHyFIS-Yager network is a multilayer neural network based fuzzy system. The architecture of the proposed model is shown in Fig. 1 and the network consists of five layers of nodes. Layer 1 consists of the input linguistic nodes; layer 2 consists of the antecedent nodes; layer 3 is the rule nodes; layer 4 is the consequent nodes; and layer 5 consists of the output linguistic nodes. For clarity, the variables i, j, k, l , and m are used in the subsequent sections to refer to nodes in the layers 1–5, respectively. In the SoHyFIS-Yager model, each input node $IV_i, i \in \{1 \dots n_1\}$ in layer 1

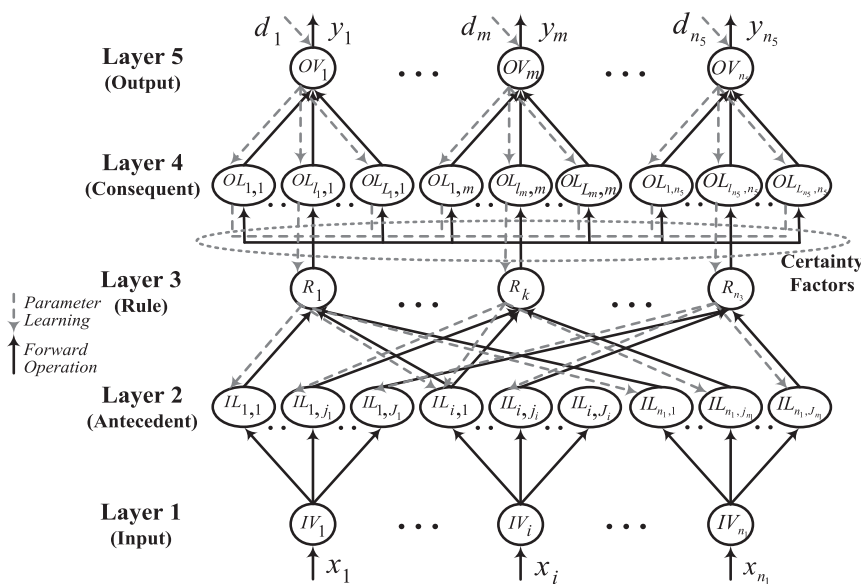

Fig. 1. Structure of SoHyFIS-Yager.





ID	Title	Pages
387297	SoHyFIS-Yager: A self-organizing Yager based Hybrid neural Fuzzy Inference System	13

Download Full-Text Now



<http://fulltext.study/article/387297>

 **FullText.study**

-  **Categorized Journals**
Thousands of scientific journals broken down into different categories to simplify your search
 -  **Full-Text Access**
The full-text version of all the articles are available for you to purchase at the lowest price
 -  **Free Downloadable Articles**
In each journal some of the articles are available to download for free
 -  **Free PDF Preview**
A preview of the first 2 pages of each article is available for you to download for free
-

<http://FullText.Study>