

Boosting the Throughput of LED-Camera VLC via Composite Light Emission

Yanbing Yang^{1,2} Jun Luo¹

¹School of Computer Science and Engineering, Nanyang Technological University, Singapore

²College of Computer Science, Sichuan University, P.R. China

Email: {yyang017, junluo}@ntu.edu.sg

Abstract—LED-Camera Visible Light Communication (VLC) is gaining increasing attention, thanks to its readiness to be implemented with Commercial Off-The-Shelf devices and its potential to deliver pervasive data services indoors. Nevertheless, existing LED-Camera VLC systems employ mainly low-order modulations such as On-Off Keying (OOK) given the simplicity of their implementation, yet such rudimentary modulations cannot yield a high throughput. In this paper, we investigate various opportunities of using a high-order modulation to boost the throughput of LED-Camera VLC systems, and we decide that Amplitude-Shift Keying (ASK) is the most suitable scheme given the limited operating frequency of such systems. However, directly driving an LED to emit different levels of luminance may suffer heavy distortions caused by the nonlinear behavior of LED. As a result, we innovatively propose to generate ASK using the composition of light emission. In other words, we digitally control the On-Off states of several groups of LED chips, so that their light emissions compose in the air to produce various ASK symbols. We build a prototype of this novel ASK-based VLC system and demonstrate its superior performance over existing systems: it achieves a rate of 2 kbps at a 1 m distance with only a single LED luminaire.

Index Terms—Visible Light Communication; Collaborative Transmissions; Amplitude-Shift Keying

I. INTRODUCTION

While WiFi is becoming more and more pervasive, using it as an information broadcast service (e.g., delivering notices, advertisements, or even emergency alerts) is still not an option mainly due to its relatively high overhead and lack of location awareness. As an alternative, high-speed Visible Light Communication (VLC) based on Light Emitting Diodes (LEDs) and Photo-Diodes (PDs) [1]–[3] is yet to see its avatar after decades of theoretical studies, since it is severely challenged by the interference in a real-life scenario. Consequently, LED-Camera VLC [4]–[10], with its sole reliance on Commercial-Off-The-Shelf (COTS) devices,¹ rises as a readily deployable service, strongly backed by the increasing adoption of LED lighting infrastructure and the ever-growing popularity of camera-equipped smartphones. Moreover, using a camera as a receiver can largely eliminate interference suffered by LED-PD VLC [18], thanks to the inherent spatial division at the

receiver [8]. Nevertheless, the limited frequency response of camera makes it hard to gain a sufficiently high data rate.

Various seminal approaches have been taken to improve LED-Camera VLC with respect to both throughput and reliability in the past few years [5]–[8], [19]. Earlier proposals such as [4], [20] make use of reflected light as the communication media and adopt On-Off Keying (OOK) as the basic modulation scheme, so the achievable data rate is reported to be only a few bytes per second. Recent proposals manage to raise the data rate to kbps level by switching to direct light as communication media [6], engineering advanced modulation schemes such as Color-Shift Keying (CSK) [7], and applying sophisticated channel coding such as rateless codes [9]. However, these systems all share a bottleneck on the receiver side, i.e., the smartphone camera, although an LED transmitter can be modulated at a frequency up to GHz. Basically, the rolling shutter effect of a CMOS camera exploited by LED-Camera VLC offers a frequency response only up to a couple tens of kHz [6], [8], leading to a relatively low optical clock rate confining the performance of such a system. Moreover, the nature of rolling shutter also limits usable modulation schemes, preventing more advanced modulation techniques such as phase-shift from being applied. According to the IEEE standard for VLC [21], the data rate of a practical VLC system should be at least tens of kbps, so there is still a big gap between existing LED-Camera VLC systems and an applicable VLC data service.

One of the major reasons causing a low data rate of existing LED-Camera VLC is the commonly applied low-order modulation, such as OOK.² In fact, there is even no systematic study on what modulation schemes can be applied for LED-Camera VLC; OOK is commonly applied only due to its simplicity. In this paper, we make an attempt to improve the data rate of LED-Camera VLC by first answering the following question: *what are the feasible modulation schemes under a low optical clock rate?* Whereas the answer reveals (as expected) Amplitude-Shift Keying (ASK) as the only choice, it also suggests that a straightforward implementation of ASK by digitally driving the luminance of LEDs can suffer severe distortion induced by the nonlinear behavior of an LED. Moreover, demodulating a high-order ASK under

This work was supported in part by the AcRF Tier 2 Grant MOE2016-T2-2-022, the DSAIR Center at NTU, and National Natural Science Foundation of China under Grant No. 61373091.

¹Another type of COTS-enabled VLC system adopts screen as the transmitter [11]–[17], so its usage is confined by the availability of large screens.

²The CSK adopted by ColorBars [7] is high-order modulation inspired by Wavelength-Division Multiplexing (WDM), yet the resulting low signal strength has reduced the working transmission distance to a few centimeters.

kHz clock rate is non-trivial because of the reduced symbol distance compared with OOK. To this end, we set out to devise a new modulation mechanism termed *Composite Amplitude-Shift Keying* (CASK) for LED-Camera VLC. CASK controls the ON-OFF states of several groups of LED chips individually so that the composite light emission exhibits various levels of grayscale (i.e., amplitude-shift). Also, CASK employs a delicate demodulation algorithm to properly recognize grayscale symbols under a kHz-level clock rate. In summary, our main contributions are as follows:

- We systematically investigate the applicability of various modulation schemes under LED-Camera VLC.
- We propose the novel idea of generating ASK though physical light composition, in order to overcome the nonlinear distortion.
- We engineer an efficient demodulation algorithm to handle the reduced symbol distance under a high order ASK.
- We build CASK into a practical VLC prototype; it adopts COTS LEDs as the transmitter and an Android phone as the receiver.
- We conduct extensive evaluations on this prototype to demonstrate the efficacy of CASK in boosting the throughput of LED-Camera VLC.

We focus only on using a single COTS LED luminaire as the transmitter in this paper. Applying rateless codes to combine several transmitters in a collaborative transmission manner has been proposed in [8], and multiple transmitters operating CASK should be compatible with such a collaborative extension for further improving VLC throughput.

II. WHY ASK? PRELIMINARY STUDY AND MOTIVATION

This section serves as a research on the feasibility of various modulation schemes for LED-Camera VLC (thus also a motivation for our work), as well as a literature survey on recent proposals for such systems.

A. Rolling Shutter and OOK Basics

Rolling shutter is a special property of CMOS cameras, i.e., the pixels of a single frame are not exposed and sampled together but rather sequentially in a column-by-column manner. As a result, we may deem the columns exposed at the same time a sampler to a time-varying process in terms of certain lighting property (e.g., luminance and tone) [4]. As a special case, OOK modulates input signal onto the ON-OFF states of an LED, and the resulting bright-dark luminance process is sampled by a CMOS camera (with its rolling shutter) as bright-dark bands in a frame. We omit the detailed illustration due to the page limit, but rather refer the readers to Figure 3 of [6]. Here we only use a frame sampled by our CASK receiver, see Fig. 1(a), to assist in highlighting a few key points.

First of all, rolling shutter has two crucial parameters, namely rolling-shutter frequency F_r and scanning (column) width W_r [8]. If a modulation process generates symbols at frequency F_m , the necessary condition for an LED-Camera VLC system to work is $F_m \leq F_r$. Although F_r may vary with different smartphones, it is normally at the level of 20 kHz.

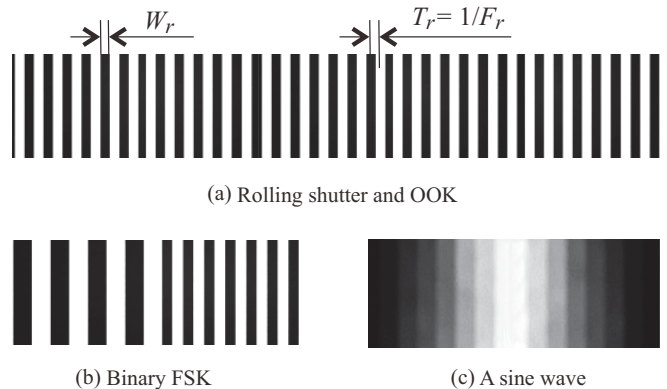

Fig. 1. Illustrating rolling shutter and modulations. (a) When setting $F_m = F_r$, the time lapse between sampling two bands is exactly $1/F_r$, and the width of each band is W_r . (b) BFSK constructed by two OOKs with different frequencies. (c) A sine wave sampled by rolling shutter.

Therefore, given that W_r is only a couple of pixels and the communication is asynchronous (i.e., the rolling shutter sampling may not be aligned with the modulation process), $F_m \leq 10$ kHz is needed to guarantee a measurable symbol width in a frame.

Secondly, though it is feasible to have $F_m \ll F_r$, the resulting symbol width grows as F_m decreases. Since the number of symbols contained in a frame is bounded by the minimum between the screen width and the width of the transmitter's image (a.k.a., Region of Interest, or RoI [22]), widening individual symbols can only reduce the symbol rate (hence the throughput), given a fixed frame rate of 30 fps [8].

Last but not least, as the transmitter piggybacks on an existing lighting infrastructure, it is necessary that the modulation process does not generate visible flickers on the individual LED luminaires. This demands that the modulation process should not produce low frequency components. In other words, F_m is bounded below by a couple of kHz. While the limited operating frequency of rolling shutter receivers confines the selection of modulation schemes (as will be discussed soon), their one-dimension sampling nature rules out the feasibility of the two-dimensional bar codes like coding mechanism commonly used by Screen-Camera VLC [12]–[17].

B. FSK and PWM Are Not Beneficial

Frequency-Shift Keying (FSK), as a very conventional RF modulation scheme, has been adopted by RollingLight [6], a seminal proposal that introduces direct light to LED-Camera VLC. Basically, an FSK symbol consists of several bright-dark bands caused by an OOK modulation running at a given frequency, shown in Fig. 1(b). Apparently, this scheme could substantially reduce the symbol rate as basic OOK only requires one band per symbol. Moreover, FSK has to run at frequencies lower than F_m (which is already below 10 kHz) in order to produce different symbols. As a result, FSK may only yield a data rate of several bytes per second [6].

If we push the limit of FSK to the extent of only two bands per symbol, we end up with Pulse-Width Modulation

(PWM). However, ideal PWM is not feasible given the limit of rolling shutter. As we mentioned early, rolling shutter samples a time-varying process with a granularity (pulse width) of W_r . Therefore, symbol width can only be a multiple of W_r , causing a high order modulation to produce very large symbol width and thus contracting its contribution to the data rate. Moreover, frequently changing the frequency of the ON-OFF modulation process may create low frequency components that in turn lead to visible flickers on LED luminaires.

C. Waveform Should Be Avoided in Modulation

Phase-Shift Keying (PSK) related modulation schemes (in particular Quadrature Amplitude Modulation, or QAM) are widely used in RF communications [23]. However, all such methods rely on sampling complicated waveforms at the receiver with pulse sequences of some very high frequency (notably at GHz level). According to our earlier analysis on rolling shutter, its sampling ability is far from sufficient to handle waveforms, unless we allow a super wide waveform/symbol to be produced, as shown by Fig. 1(c), thus ruining the data rate. For the same reason, Orthogonal Frequency-Division Multiplexing (OFDM), another popular RF modulation scheme that is envisioned also for LED-PD (Photo-Diode) VLC [24], [25], is not viable for COTS-based VLC either.

The extreme version of PSK, with a super narrow waveform, is Pulse-Position Modulation (PPM). It is used in Ultra-Wide band (UWB) [26] and is adopted by DarkLight [27] for enabling an LED-PD VLC to operate under light-off scenarios. As the bandwidth required by PPM is extremely high (MHz level for DarkLight), the limited operating frequency of rolling shutter certainly cannot match.

D. CSK May Not Scale Up

Inspired by Wavelength-Division Multiplexing (WDM), ColorBars [7] exploits Tri-LED's ability of producing a wide range of colors to generate a high order modulation termed Color-Shift Keying (CSK). In fact, CSK can also be deemed as a kind of FSK, where the symbol frequency is determined by the light wavelength rather than the duty cycle rate of OOK (as used by RollingLight [6]). As ColorBars uses a single Tri-LED chip to implement a VLC system with a transmission distance only up to a few centimeters, the key question here is whether CSK scales up to a full lighting infrastructure. A first but relatively minor issue is that Tri-LEDs are more expensive than phosphor-coated white LEDs commonly used for commercial lighting, so it is quite unlikely that we will see large scale adoption of Tri-LEDs in real life. Secondly but more importantly, applying CSK to COTS LED luminaires requires a close synchronization among tens to hundreds LED chips. This, on one hand, makes the driver extremely complicated, and on the other hand, it results in a rather unreliable modulation whose color symbols are prone to distortion caused by asynchronous light emissions. Thirdly, a slight loss of synchronization among LED chips can also

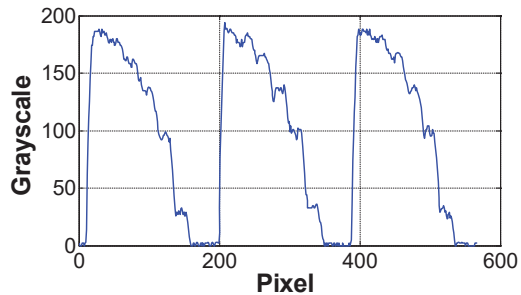

Fig. 2. LED nonlinearity distorts 8-ASK symbols.

break the balanced emission designed by CSK to avoid flicker, causing visible flickers on the individual LED luminaires.

E. ASK Is The Last Choice, But ...

With our aforementioned analysis, ASK appears to be the only remaining choice. An ideal ASK extends OOK by producing grayscale bands between the brightest and the darkest levels, driven digitally by some input signals. Nonetheless, LEDs are well known for their nonlinear behavior [28]; in fact, the same reason has long been one of the major challenges for the development of OFDM-based LED-PD VLC. Essentially, while the given input signal indicates 2 in an 8-ASK, the output at an LED can severely deviate from $2/7$ grayscale (as shown by Fig. 2), and this distortion may vary with different types of LEDs and ambient conditions (e.g., temperature) as well. As a result, existing modulation schemes designed for LED-PD VLC all confine their (LEDs) output dynamic range to a pseudo-linear section of LED transfer characteristics [25], [29]. Such a makeshift may work for high-power LED-PD VLC, but it is certainly not feasible for supporting ASK given COTS LEDs, as it would significantly reduce the symbol distance, causing a much higher error rate in demodulation. Consequently, novel physical layer techniques have to be in place to handle LED nonlinearity.

III. CASK: MODULATION AND DEMODULATION

In this section, we first elaborate how our novel CASK works on the transmitter side to generate ASK symbols via physical light composition, replacing conventional driver circuits that are both distortion-prone and power-intensive. Then we present our carefully designed demodulation process for recognizing CASK symbols on the receiver side. We omit the descriptions of common blocks in LED-Camera VLC, such as Forward Error Correction (FEC) and RoI extraction [5], [8].

A. From Data to Light

The transmitter in a conventional ASK-based VLC system, as shown in Fig. 3(a), first divides a data stream into packets with FEC encoding to combat packet loss. Then the encoded packets are modulated to various ASK symbols, followed by a Digital-to-Analog Converter (DAC) to convert digital signals to analog domain. A Power Amplifier (PA) is finally added to deliver sufficient power for driving the LED transmitter. However, such a circuit may cause significant symbol distortions due to both the LED nonlinearity explained in

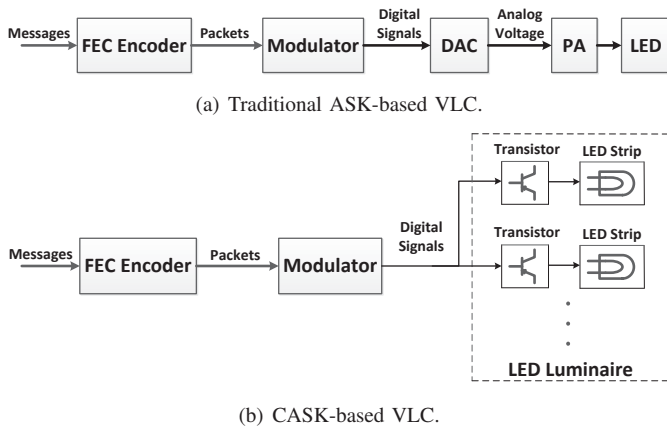

Fig. 3. System block diagrams of two different VLC transmitters.

Section II-E and the involvement of analog waveform sensitive to noise corruption. In addition, the DAC and PA are often considered as power-intensive components, potentially adding more energy consumption on the lighting infrastructure.

Our idea of CASK produces ASK symbols with only digital control signals as successfully used by OOK and FSK modulations. Inspired by the spatial filtering technique for beamforming in RF technology [30], it is possible to constructively combine the light emissions from several groups of LED chips to form different luminance levels (hence ASK symbols). Meanwhile, commercial LED luminaires often consist of multiple LED chips. Intuitively, if we separate these chips into several groups and control their ON-OFF processes according to the modulated signal, their composite light emissions will generate corresponding ASK symbols. Based on this idea, we propose CASK modulation circuits that totally get rid of the analog part, as shown in Fig. 3(b). We provide the details on how CASK produces ASK symbols in the next section.

B. Composite Light Emission for ASK Symbol Generation

Under conventional OOK, a whole LED luminaire is toggled between ON and OFF states. Such a modulation ignores

TABLE I
ASK SYMBOLS PRODUCED BY DIFFERENT SCHEDULES OF LED STRIPS.

Symbols		ON-OFF schedules of LED strips						
		S_6	S_4	S_2	S_1	S_3	S_5	S_7
OOK	A0	OFF	OFF	OFF	OFF	OFF	OFF	OFF
	A1	ON	ON	ON	ON	ON	ON	ON
4ASK	A0	OFF	OFF	OFF	OFF	OFF	OFF	OFF
	A1	OFF	OFF	ON	ON	OFF	OFF	OFF
	A2	ON	ON	OFF	OFF	ON	ON	ON
	A3	ON	ON	ON	ON	ON	ON	ON
8ASK	A0	OFF	OFF	OFF	OFF	OFF	OFF	OFF
	A1	OFF	OFF	OFF	ON	OFF	OFF	OFF
	A2	OFF	OFF	ON	ON	OFF	OFF	OFF
	A3	OFF	OFF	ON	ON	ON	OFF	OFF
	A4	ON	ON	OFF	OFF	OFF	ON	ON
	A5	ON	ON	OFF	OFF	ON	ON	ON
	A6	ON	ON	ON	OFF	ON	ON	ON
	A7	ON	ON	ON	ON	ON	ON	ON

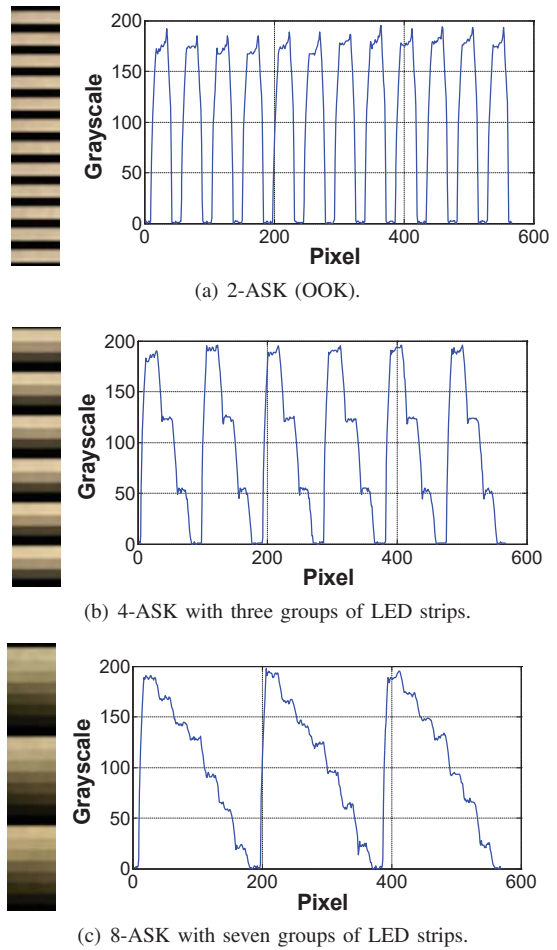

Fig. 4. CASK symbols produced by light composition.

the nature of commercial LED luminaires that often contain multiple LED chips. Given an LED luminaire consisting of N LED chips and according to how many LED chips are ON at a given moment, the emitted light intensity should have $N + 1$ levels, potentially resulting in $(N + 1)$ -ASK with each luminance level representing a symbol. Using such a modulation may boost data rates of an OOK VLC system by $\log_2(N + 1)$ -fold in theory. Apparently, the higher value of N , the more bits can be represented by each symbol, raising the order of the ASK. However, a higher N also causes a reduced symbol distance, potentially increasing the error rate in demodulation. By far, we have tested up to 8-ASK with a reasonable transmission distance at meter level. Fig. 4 shows the ASK symbols of 2-, 4-, and 8-ASKs generated by our CASK prototype. In reality, an LED luminaire can have more chips than the order of ASK, so we group the chips into strips, and consider each strip as a controllable unit.

In our current prototype as described in IV-A, we employ 7 controllable LED strips forming an LED luminaire (a VLC transmitter), so that it can yield maximum 8-ASK in theory. Here we take 4-ASK as an example to explain how to form specific ASK symbols via composite light emission. Since 3 LED strips are enough to produce 4-ASK, we simply group LED strips to reduce the order of ASK. As summarized in

Table I, we switch all LED strips OFF to generate Amplitude-0 (or A0), then the middle two strips ($S1$ and $S2$)³ are turned ON and others OFF to form Amplitude-1 (or A1). Subsequently, the rest 5 LED strips ON and others OFF generate Amplitude-2 (or A2) (such a symmetrical setting is needed for flicker suppression as analyzed in Section III-C). Finally, all LED strips are turned ON for Amplitude-3 (or A3). As generalizing these to higher order ASKs is straightforward, we omit the detailed explanations for 8-ASK but refer readers to Table I.

C. Flicker Suppression with Balance Coding

As LED transmitters piggyback on a lighting infrastructure, transmissions should cause no visible flicker. Unfortunately, directly using CASK would not be flicker-free. For example, a symbol sequence of A0, ..., A3, ..., A0, ... would generate a low frequency component with high power, causing visible flicker. For existing OOK or FSK VLC systems, Run-Length Limited (RLL) codes (as recommended in IEEE 802.15.7 [31]) are commonly used to maintain DC balance and bit disparity, but these codes are not devised for a high-order ASK. Therefore, we propose a new coding scheme inspired by Manchester coding, where each symbol is extended to include itself and its complementary symbol, i.e., a symbol A_i becomes $A_iA(3-i)$ for 4-ASK. This coding, on one hand, maintains DC balance, and on the other hand, boils down to Manchester coding for individual LED strips. Therefore, CASK enhanced with our new coding is guaranteed to be flicker-free, and we have conducted user study to confirm it.

D. ASK Demodulation on Smartphone Receiver

In an LED-Camera VLC system, the receiver captures sent messages via its rolling shutter camera, and the transmitter is projected as banded sections (RoIs) carrying information in a frame. Therefore, the demodulator first extracts all RoIs in a frame, and then converts those bands into a grayscale sequence. For conventional OOK modulated signals, a pre-configured threshold can be used to distinguish only two amplitude states: bright (A1) or dark (A0). However, such a trivial threshold configuration is not suitable for CASK, since a higher order ASK reduces symbol distance. This, on one hand, complicates demodulation, and on the other hand, makes a symbol more sensitive to noise and tonal range variation.

Inspired by the preamble setting in CDMA, a few successive brightest symbols are inserted in a packet header. As a result, the header contains the grayscale information of the whole packet as shown in Fig. 5, and the tonal range variation across the frame can be further derived by measuring multiple headers. Consequently, we can measure the grayscale distribution in a frame so as to set appropriate thresholds for demodulating symbols. Specifically, the demodulator first identifies headers by using a rough threshold based on tonal range distribution in the previous demodulation stage. Once all headers in a frame are located, a packet along with its grayscale envelope is

³Other settings either reduce the symbol distance (e.g., only $S1$ ON) or break the symbol balance (e.g., 3 strips ON for A1 and 5 strips ON for A2).

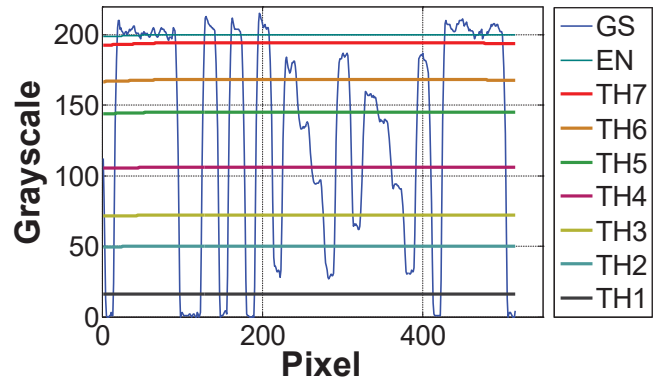

(a) A packet with 8-ASK symbols under 3 kHz

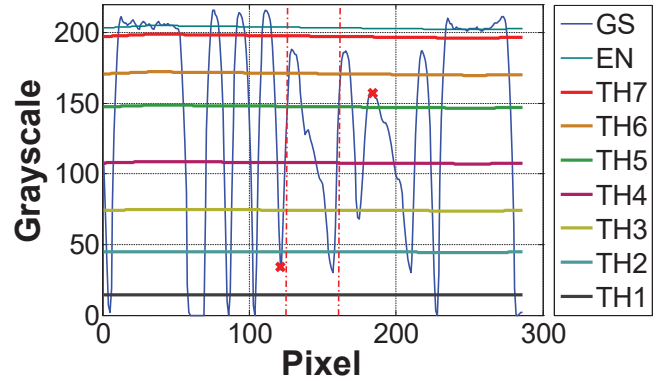

(b) A packet with 8-ASK symbols under 5 kHz

Fig. 5. A packet with 8-ASK symbols under different transmission frequency; thresholds for demodulating the packet are marked in different colors.

determined by two consecutive headers as shown in Fig. 5 (EN in the figure). Based on this envelope, the detection thresholds for all symbols (i.e., lower bounds in grayscale that are relative to the envelope) are set empirically to maximize the chance for correct demodulation; they are inherently stable because they are produced by physical composition. In the following, we present the detailed demodulation process for retrieving data bits from a given packet (a section of a banded image).

1) *Demodulation Based on Width*: In a conventional OOK-based system, a symbol is recognized by detecting the width of a band using a bisection threshold to its grayscale. To combat the blooming effect that causes bright bands wider than the darker ones, [8] proposes a method by reasoning on the widths of bright/dark bands in a clustered manner. Nevertheless, a higher order ASK modulation requires a substantially different demodulation scheme because of its reduced symbol distance in grayscale as shown by Fig. 4. In addition, a higher transmission frequency further complicates demodulation, because symbols (bands) around the midtone get their width significantly shrunk, as demonstrated by comparing the two packets transmitted at two different frequencies in Fig. 5. Therefore, the width-based demodulation alone is not suitable anymore as the substantially narrowed bands are much more prone to the corruption by the blooming effect.

Fig. 5(b) also reveals another issue: a symbol can hardly get stable before transiting to next symbol at a higher frequency.

Algorithm 1: Identifying Symbol in ASK Demodulation.

Data: $S, G'(i), G''(i)$ **Result:** S_A **begin**

```
 $S_A \leftarrow \emptyset;$ 
while  $j < |S|$  do
  if  $G'(i)$  crosses zero in band  $j$  then
     $S_A \leftarrow S_A \cup \{S(j)\};$ 
  else
    if  $G'(i) > 0$  and  $G''(i)$  crosses zero from
      negative to positive then
         $S_A \leftarrow S_A \cup \{S(j)\};$ 
    else
      if  $G'(i) < 0$  and  $G''(i)$  crosses zero from
        positive to negative then
           $S_A \leftarrow S_A \cup \{S(j)\};$ 
     $j \leftarrow j + 1;$ 
```

This transiency is harmful as grayscale values cannot be solely relied upon for demodulation. For example, if two symbols A0 and A7 are sent in a row, there must exist pixels with a grayscale value corresponding to other symbols (say A4) between them, and there is no way to differentiate these “fake symbols” from those becoming transient due to a high frequency. Consequently, we need to upgrade the width-based detection and value-based demodulation to a new scheme that takes both variance and transiency into consideration.

2) *Leveraging the Gradient of Grayscale:* Apparently, a feasible approach should first determine which bands are representing valid symbols, before converting them into data bits. A useful observation drawn from Fig. 5(b) is that the gradient in grayscale is much more indicative than the grayscale value itself. Considering again the aforementioned example, the gradient between two consecutive symbols A0 and A7 should always be steeper than having another symbol, say A4, between them, not matter how transient the band representing that symbol is. Therefore, our CASK demodulation extracts grayscale gradient as an additional criterion to be combined with width and value.

Essentially, we look into the grayscale function $G(i), i = 1, 2, \dots, n$ of pixel brightness in a frame, where n is the total number of horizontal pixels and $G(\cdot)$ returns the average pixel brightness for a given column. In an interval between any two neighboring thresholds, a valid symbol causes a certain gradient variance (determined by the transmission frequency) that distinguishes itself from other valid symbols or no symbol. In particular, $G'(\cdot)$, the first-order derivative of $G(\cdot)$, should approach to zero where a certain symbol exists. Since $G(i)$ is discrete grayscale values of given pixels, the value of $G'(i)$ may not exactly equal to zero. As a result, we examine where the value of the finite difference of $G(i)$ goes across zero. Basically, **Algorithm 1** first makes use of $G'(i)$ crossing zero to identify local minimal and/or maximal, which represents candidate symbols such as A1 and/or A5 as shown in Fig. 5(b)

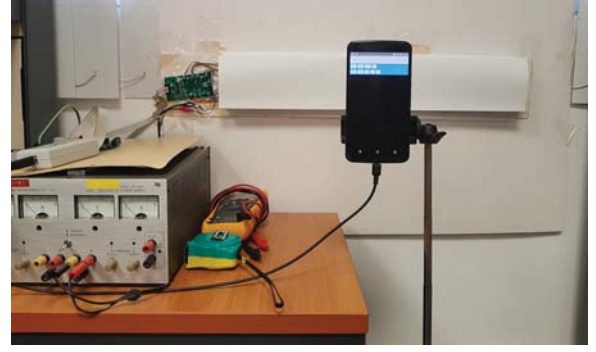

Fig. 6. Testbed setting for experiments.

(marked by a red \times). In order to detect potential symbols appearing transiently in-between two other symbols (e.g., A4 and A3 between A6 and A1, the section in Fig. 5(b) between the two vertical red dash-dotted lines), the algorithm further employs the second-order derivative $G''(i)$ crossing zero to detect positive and/or negative inflection points as candidates for such transient symbols. All these candidate symbols $\{S(j)\}$ are put into the valid symbol stream S_A , and the demodulation procedure compares them with the thresholds so as to convert them into bits.

To summarize, the CASK demodulator first locates all headers by measuring brightness and width information, and extracts a potential packet between two consecutive headers. For each potential packet, all pixels (averaged per column) will be mapped to potential symbols using the dynamically configured thresholds to obtain a symbol stream S . Then the judging procedure **Algorithm 1** begins to recognize valid symbols and discard illegal ones. Finally, the valid symbols are mapped into bits to form candidate packets, and upon receiving sufficient packets, Raptor decoding procedure (omitted for brevity) is triggered to recover original messages.

IV. SYSTEM EVALUATION

In this section, we evaluate the performance of our CASK modulation scheme with compositing light emissions and investigate achievable communication capacity under various ASK symbols and transmission frequency. We then discuss the results of our field experiments with respect to various metrics.

A. Experiment Settings

We build the transmitter with commercial LED strips and the self-developed LED driver controlling individual LED strips with low-cost transistors. The LED luminaire is made of 7 LED strips each carrying 36 LED chips, hence a size of 60 cm \times 7 cm similar to a common fluorescent luminaire. We make a cover for the transmitter mimicking the commercial LED luminaire as otherwise it is too dazzling. Fig. 6 shows our testbed settings for field experiments. We slightly tune the current-limiting resistor for each LED strip on the driver to maintain a proper linear scaling in grayscale.

In order to better evaluate the performance of various CASK, we fix the packet structure as a preamble of five successive brightest symbols under each order of CASK

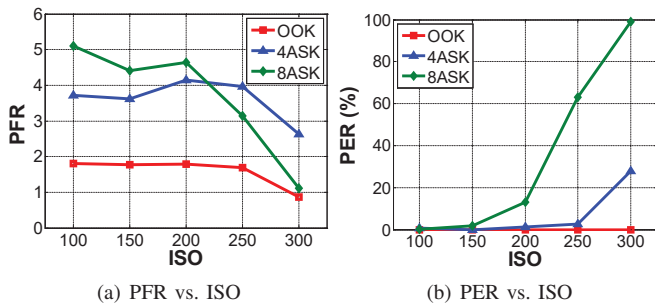

Fig. 7. PFR and PER with a varying ISO configuration.

modulation, e.g., A3 in 4-ASK and A7 in 8-ASK, and a single darkest symbol A0 to indicate the header, followed by 24 data bits (8-bit packet sequence number and 16-bit payload), and finally ended with a A0. Under such a configuration, the transmitter sends identical payload bits but with different orders of CASK modulation, e.g., 2- 4- and 8-ASK. We also consider OOK (2-ASK) as a baseline; it represents existing LED-Camera VLC systems (e.g., [8]). Raptor coding is used as an FEC method to combat packet loss. Thus a message contains k packets, and Raptor coding encodes original k packets at the rate of $n = 1.25 \times k$ to generate encoded packets. To simplify our evaluation, we fix $k = 26$ for throughput test and set the decoding overhead as 0.15.

A Nexus 6 smartphone is used as the receiver, and we build demodulation/decoding into an Android application on it. Basically, we configure the Nexus 6's camera to work in the preview mode, and the frame rate is 30 fps. We fix the exposure time to $1/7500$ s. Besides throughput, we also evaluate the performance of various CASK modulation in terms of *Packet Frame Ratio* (PFR) and *Packet Error Rate* (PER). PFR is the ratio between the successfully identified packets (those between two consecutive headers) and totally used frame number, which makes sense as it directly indicates how many packets a frame can carry under various CASK modulations. PER is the percentage of wrongly demodulated packets out of all successfully identified ones. Each experiment includes 50 sessions and every session contains 200 packets (before FEC); we report the average results over all sessions, except for throughput where peak values are reported as well.

B. ISO Impact on Demodulation

Apparently, a suitable ISO configuration for the camera receiver is crucial since it directly impacts on band brightness (hence SNR). We first study the impact of camera setting on PFR and PER in this section. Fig. 7 reports the experiment results. It is expectable that increasing ISO degrades both PFR and PER as it brings serious blooming effect resulting in boundary blurring between neighboring symbols. It is also obvious that 8-ASK is more sensitive to ISO setting comparing with the other lower order modulations, because the symbol distance is shrinking with a higher order CASK modulation. Nevertheless, CASK, e.g., 4- and 8-ASK, still maintains a stable communication channel with an ISO configuration of below 200. Therefore, the ISO is by default configured at 200

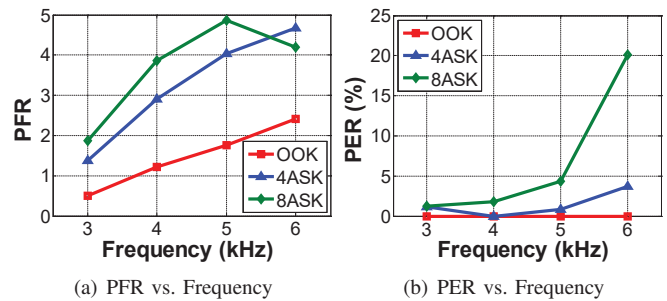

Fig. 8. PFR and PER with a varying transmission frequency.

for the remaining experiments to maintain a reasonable trade-off between throughput and communication range. We leave it as our future work to integrate automatic ISO configuration into the demodulator.

C. Channel Property

We hereby investigate demodulation performance under different experiment settings.

1) *Demodulating with Increased Frequency*: As analyzed in III-D, a higher transmission frequency may yield a higher data rate, because a frame/RoI can carry more symbols (also packets). However, a higher frequency complicates demodulation as it significantly shrinks the width of the bands as shown in Fig. 5. Therefore, we first evaluate demodulation performance under different frequency in terms of PFR and PER. We vary the frequency from 3 kHz to 6 kHz, and report the PFR and PER results with three different orders of CASK modulation in Fig. 8(a) and 8(b), respectively.

As we would expect, the higher order CASK yields higher PFR, because given identical transmitted payload (valid bits) the amount of mapped symbols is less. As a result, 4- and 8-ASK always have higher PFR than simple OOK as shown in Fig. 8(a). However, the PER is getting higher with an increasing frequency as shown in Fig. 8(b), since symbols are prone to be interfered by various noises such as blooming at the higher frequency resulting in thinner bands. It is quite intuitive that OOK achieves the lowest PER among three evaluated CASK modulations, at the cost of a much lower PFR (thus lower throughput as evaluated in Section IV-D1). In sum, the high order CASK modulations, e.g., 4- and 8-ASK, always achieve higher PFR compared with the simple OOK meanwhile maintain reasonable PER under 5 kHz, strongly demonstrating that the CASK has the ability to boost data rates. We hereafter set the transmission frequency at 5 kHz.

2) *Attenuation in Communication Range*: We then evaluate the channel property with varying the transmission distance under three adopted CASK modulation schemes. We change the distance from 0.2 m to 1 m due to the limited size of the used LED transmitter in our testbed, but it is quite easy to extend the transmission distance by using a longer LED luminaire [8]. Again, as higher order modulation schemes embed more bits into a symbol leading to a shorter packet size in symbol level, resulting in 4- and 8-ASK double PFR comparing with OOK as illustrated in Fig.9(a). In particular,

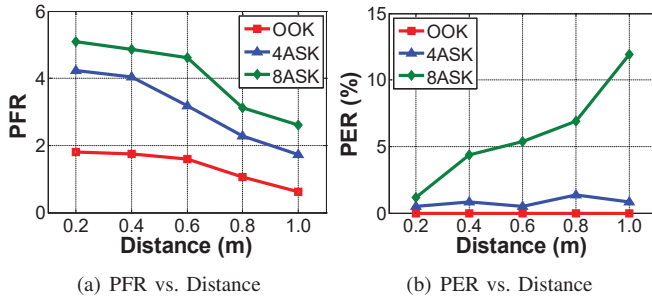

Fig. 9. PFR and PER with a varying distance.

the frame/RoI may hardly contain an entire packet with OOK at a distance of 1 m, while it can still receive two packets (or more) under 4- or 8-ASK. Such a higher PFR offered by the high order CASK definitely reveals its ability in boosting data rates. Moreover, a longer distance results in lower signal strength at the receiver side, hence reducing the grayscale value of bands. Fig. 9(b) intuitively shows that both PFR and PER degrade with an increasing distance for all CASK modulation schemes. Since OOK has a larger symbol distance in grayscale (maximum vs. minimum), the communication distance has the least impact on its demodulation performance leading to a stable PER. Nevertheless, higher order CASK modulation schemes still maintain reasonable PER of less than 2% under 4-ASK and 13% under 8-ASK within 1 m.

D. Throughput

In this section, we report the throughputs offered by various CASK modulation schemes. Whereas the above evaluations on channel property demonstrate possible communication ability with various CASK modulation schemes, the throughput is directly evaluated from the perspective of realistic application. The throughput in this paper is computed as totally recovered data bits after Raptor decoding divided by the transmission time, here we fix the length of a message as 26 original packets (i.e., $k = 26$ as mentioned in Section IV-A). The transmission time is defined as the time span from starting receiving the first frame till the transmitted message gets decoded. We conduct experiments with OOK, 4-ASK, and 8-ASK based on our testbed, and report both maximum and average throughputs for each experiment as mentioned in Section IV-A. In particular, we apply the complementary coding scheme proposed in Section III-C to 4- and 8-ASK, and employ Manchester coding for OOK to maintain DC balance so as to avoid flicker. We refrain from comparing CASK with CSK used in ColorBars [7], as it uses a Tri-RGB LED chip that is very hard (if not impossible) to scale up to full luminaires for a longer transmission distance, as explained in Section II-D.

1) *Throughput vs. Frequency*: As studied in Section III-D and Section IV-C1, the transmission frequency impacts on the demodulation performance (hence the throughput). We hereby evaluate the throughput with various CASK modulation schemes at a varying transmission frequency in this section. As shown in Fig. 10, both peak and average data rates get increasing with a higher frequency; it is totally agreed with

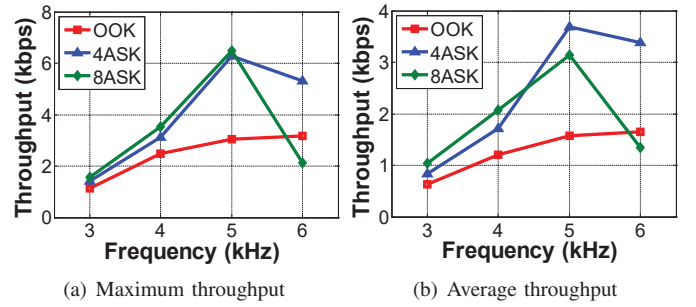

Fig. 10. Maximum and average throughput with a varying transmission frequency.

the results of PFR evaluated in Section IV-C1. 8-ASK always outperforms the other two lower order modulation schemes below 5 kHz, while 4-ASK can support a higher transmission frequency up to 6 kHz as illustrated in both Fig. 10(a) and Fig. 10(b). The benefit of 4-ASK may stem from a higher SNR with grouped LED strips as described in Section III-B and relatively reasonable demodulation complexity. Nevertheless, the higher order modulation significantly boosts data rates comparing to the simple OOK, strongly demonstrating the effectiveness of our CASK.

2) *Throughput vs. Distance*: We finally evaluate the throughput provided by CASK under a varying distance, and we report the outcomes in Fig. 11. As we expect, modulation schemes with higher order, e.g., 4- and 8-ASK, obviously produce higher data rates than that achieved by OOK at any distance thanks to a higher bit-per-symbol ratio, i.e., a higher PFR. Apparently, 8-ASK achieves a higher peak throughput than 4-ASK, but a similar average throughput comparing to 4-ASK as illustrated in Fig. 11(a) and Fig. 11(b). The benefits of the higher order CASK over OOK become more evident at a longer distance, because the higher bit-per-symbol ratio of high order CASK shortens the packet length that in turn allows more packets in one RoI. In conclusion, our CASK can deliver an average throughput up to 2 kb/s at a distance of 1 m with a single LED luminaire; it is almost fourfold throughput provided by conventional OOK [8]. If we further enhance the performance with collaborative transmission from multiple luminaires, the throughput should be high enough to support commercial applications, such as advertisement/coupon delivery in a shopping mall.

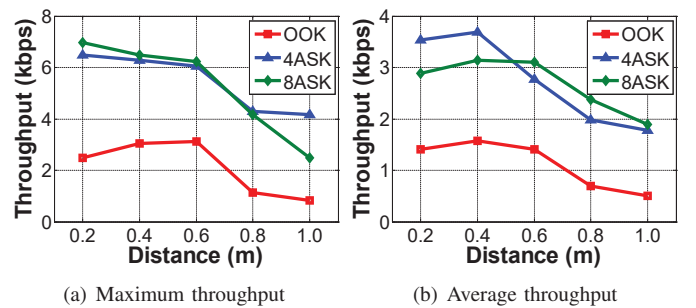

Fig. 11. Maximum and average throughput with a varying distance.

V. CONCLUSION

In order to further boost data rates for LED-Camera VLC systems, this paper presents Composite Amplitude-Shift Keying (CASK) as a method to produce high order ASK symbols via compositing light emissions. Our novel idea relies on the nature of commercial LED luminaires consisting of multiple LED chips, so that CASK can control LED chips/strips individually. As a result, light emissions get composed in the air so as to form different brightness levels (hence ASK symbols) on the receiver side. To handle the flicker issue caused CASK modulation (given that existing RLL codes are only devised for low order modulation, e.g., OOK), we have proposed a complementary coding mechanism to maintain DC balance at both symbol and individual LED chip levels for CASK modulation. Moreover, we have engineered a delicate demodulation algorithm combining conventional width-based demodulation with the gradient of grayscale to effectively demodulate CASK symbols. We have built a prototype for CASK and performed extensive field experiments based on it; the results have demonstrated that CASK can be used in LED-Camera VLC systems with commercial LED luminaires and achieve a throughput of up to 2 kbps at a 1 m distance with only a single LED luminaire, almost fourfold of the throughput offered by conventional OOK modulation. We believe that applying CASK to LED-Camera VLC would be able to push the COTS-enabled VLC towards practical deployments for realistic applications in need for reasonable data rates.

We plan to extend the scale of our prototype for conducting more comprehensive evaluations on collaborative transmission among neighboring LED luminaires to further boost data rates. We believe more experiments using a room scale prototype would help us to identify more solutions to further improve the throughput for LED-Camera VLC.

REFERENCES

- [1] H. Burchardt, N. Serafimovski, D. Tsonev, S. Videv, and H. Haas, "VLC: Beyond Point-to-Point Communication," *IEEE Communications Magazine*, vol. 52, no. 7, pp. 98–105, 2014.
- [2] S. Pergoloni, M. Biagi, S. Rinauro, S. Colonnese, R. Cusani, and G. Scarano, "Merging Color Shift Keying and Complementary Pulse Position Modulation for Visible Light Illumination and Communication," *IEEE/OSA Journal of Lightwave Technology*, vol. 33, no. 1, pp. 192–200, 2015.
- [3] J. C. Chau, C. Morales, and T. D. Little, "Using Spatial Light Modulators in MIMO Visible Light Communication Receivers to Dynamically Control the Optical Channel," in *Proc. of the 13th EWSN*, 2016, pp. 347–352.
- [4] C. Danakis, M. Afgani, G. Povey, I. Underwood, and H. Haas, "Using a CMOS Camera Sensor for Visible Light Communication," in *Proc. of 31th IEEE GLOBECOM Workshop*, 2012, pp. 1244–1248.
- [5] Y. Kuo, P. Pannuto, K. Hsiao, and P. Dutta, "Luxapose: Indoor Positioning with Mobile Phones and Visible Light," in *Proc. of the 20th ACM MobiCom*, 2014, pp. 447–458.
- [6] H. Lee, H. Lin, Y. L. Wei, H. I. Wu, H. M. Tsai, and K. Lin, "Rolling-Light: Enabling Line-of-Sight Light-to-Camera Communications," in *Proc. of 13th ACM MobiSys*, 2015, pp. 167–180.
- [7] P. Hu, P. H. Pathak, X. Feng, H. Fu, and P. Mohapatra, "Colorbars: Increasing Data Rate of LED-to-Camera Communication Using Color Shift Keying," in *Proc. of the 11th ACM CoNEXT*, 2015, p. 12.
- [8] J. Hao, Y. Yang, and J. Luo, "CeilingCast: Energy Efficient and Location-Bound Broadcast Through LED-Camera Communication," in *Proc. of the 35th IEEE INFOCOM*, 2016, pp. 1629–1637.
- [9] Y. Yang, J. Hao, and J. Luo, "CeilingTalk: Lightweight Indoor Broadcast Through LED-Camera Communication," *IEEE Trans. on Mobile Computing*, vol. 16, no. 12, pp. 3308–3319, 2017.
- [10] Y. Yang, S. Ding, J. Hao, and J. Luo, "Roaming in Connecting Light: Practical Visible Light Communication Leveraging LED Sensing," in *Proc. of the 4th ACM VLCS*, 2017, pp. 9–14.
- [11] S. Perli, N. Ahmed, and D. Katabi, "PixNet: Interference-Free Wireless Links using LCD-Camera Pairs," in *Proc. of the 16th ACM MobiCom*, 2010, pp. 137–148.
- [12] W. Hu, H. Gu, and Q. Pu, "LightSync: Unsynchronized Visual Communication Over Screen-Camera Links," in *Proc. of the 19th ACM MobiCom*, 2013, pp. 15–26.
- [13] W. Du, J. Liando, and M. Li, "SoftLight: Adaptive Visible Light Communication over Screen-Camera Links," in *Proc. of the 35th IEEE INFOCOM*, 2016, pp. 1620–1628.
- [14] T. Hao, R. Zhou, and G. Xing, "COBRA: Color Barcode Streaming for Smartphone Systems," in *Proc. of the 10th ACM MobiSys*, 2012, pp. 85–98.
- [15] A. Wang, S. Ma, C. Hu, J. Huai, C. Peng, and G. Shen, "Enhancing Reliability to Boost the Throughput over Screen-Camera Links," in *Proc. of the 20th ACM MobiCom*, 2014, pp. 41–52.
- [16] W. Hu, J. Mao, Z. Huang, Y. Xue, J. She, K. Bian, and G. Shen, "Strata: Layered Coding for Scalable Visual Communication," in *Proc. of the 20th ACM MobiCom*, 2014, pp. 79–90.
- [17] A. Wang, Z. Li, C. Peng, G. Shen, G. Fang, and B. Zeng, "InFrame++: Achieve Simultaneous Screen-Human Viewing and Hidden Screen-Camera Communication," in *Proc. of the 13th ACM MobiSys*, 2015, pp. 181–195.
- [18] R. Zhang, H. Claussen, H. Haas, and L. Hanzo, "Energy Efficient Visible Light Communications Relying on Amorphous Cells," *IEEE Journal on Selected Areas in Communications*, vol. 34, no. 4, pp. 894–906, 2016.
- [19] Y. Yang, J. Nie, and J. Luo, "ReflexCode: Coding with Superposed Reflection Light for LED-Camera Communication," in *Proc. of the 23rd ACM MobiCom*, 2017, pp. 193–205.
- [20] N. Rajagopal, P. Lazik, and A. Rowe, "Visual Light Landmarks for Mobile Devices," in *Proc. of the 13th ACM IPSN*, 2014, pp. 249–260.
- [21] S. Rajagopal, R. Roberts, and S. Lim, "IEEE 802.15.7 Visible Light Communication: Modulation Schemes and Dimming Support," *IEEE Communications Magazine*, vol. 50, no. 3, pp. 72–82, 2012.
- [22] G. Corbellini, K. Aksit, S. Schmid, S. Mangold, and T. Gross, "Connecting Networks of Toys and Smartphones with Visible Light Communication," *IEEE Communications Magazine*, vol. 52, no. 7, pp. 72–78, 2014.
- [23] *Wireless LAN Medium Access Control (MAC) and Physical Layer (PHY) Specification*, IEEE Std. 802.11, IEEE Std., 2016.
- [24] S. D. Dissanayake and J. Armstrong, "Comparison of ACO-OFDM, DCO-OFDM and ADO-OFDM in IM/DD Systems," *Journal of Lightwave Technology*, vol. 31, no. 7, pp. 1063–1072, 2013.
- [25] M. S. Mossaad, S. Hranilovic, and L. Lampe, "Visible Light Communications Using OFDM and Multiple LEDs," *IEEE Trans. on Communications*, vol. 63, no. 11, pp. 4304–4313, 2015.
- [26] E. Baccarelli, M. Biagi, C. Pelizzoni, and P. Bellotti, "A Novel Multi-antenna Impulse Radio UWB Transceiver for Broadband High-throughput 4G WLANs," *IEEE Communications Letters*, pp. 419–421, 2004.
- [27] T. Zhao, W. Kevin, and X. Zhou, "The DarkLight Rises: Visible Light Communication in the Dark," in *Proc. of the 22nd ACM MobiCom*, 2016, pp. 2–15.
- [28] H. Elgala, R. Mesleh, and H. Haas, "An LED Model for Intensity-Modulated Optical Communication Systems," *IEEE Photonics Technology Letters*, vol. 22, no. 11, pp. 835–837, 2010.
- [29] R. Mesleh, H. Elgala, and H. Haas, "LED Nonlinearity Mitigation Techniques in Optical Wireless OFDM Communication Systems," *IEEE/OSA Journal of Optical Communications and Networking*, vol. 4, no. 11, pp. 865–875, 2012.
- [30] B. D. Van Veen and K. M. Buckley, "Beamforming: A Versatile Approach to Spatial Filtering," *IEEE ASSP Magazine*, vol. 5, no. 2, pp. 4–24, 1988.
- [31] S. Rajagopal, R. Roberts, and S. Lim, "IEEE 802.15.7 Visible Light Communication: Modulation Schemes and Dimming Support," *IEEE Communications Magazine*, vol. 50, no. 3, pp. 72–82, 2012.